

LED Module M15B Series



Specification

Working Environment: -40°C~+45°C

Storage Temperature: -40°C~+50°C

Relative humidity: 10%~90%RH

Typical value of pad temperature^[1]: 70°C

IP Rating of LED Light Engine: IP68

Color Temperature (CCT)^[2]: 3000K, 4000K, 5000K, 5700K

Main Material: Aluminum 1070

Module N.W.: 0.80±0.04 kg

Note :

[1] Typical values of pad temperature is obtained based on ambient temperature of 25°C with 60w.

[2] Efficacy of 3000K is 5% lower than other CCTs.

Features

- Customized LEDs from a world-leading supplier;
- Super long lifetime(Lumen maintenance);
- Wide applicability for complex situations;
- High versatility apply for all sorts of lamps retrofit.

Application

- High bay lighting retrofit and application.
- Garden lighting retrofit and application;

Ordering Information

For example: M15B-XBA-18-2960-7040-CM

Module Model	Interface	Dimension of LEDS	Wire Material	LED Qty	Lens Model	Ra & CCT	LED Brand
M15B	X: Universal interface	B: 5050	A: CCC +VDE	18 18PCS	2960 60 DEG	7030: Ra≥70, 3000K	CM: Customized XX: Others
			C: PSE		2990 90 DEG	8040: Ra≥80, 4000K	
			H: UL			...	
			X: Others				

Performance

Model	Power (W)	Driving current (mA)	Input voltage (Vdc)	Efficacy (lm/W)	Lumens (lm)
M15B-XBA-18	60	1200	40~54	135	8100

Note : Values shown are subject to ±5%~±8% tolerance; Cable default A type;

Efficacy above is based on calculated @92% power efficiency ; Light efficacy of 3000K is 5% lower than other CCTs.

Dimensions

Diameter (mm)	H (mm)
Φ160	76

Tolerance: ±0.5mm

Available Lens Model

2960	2990
------	------

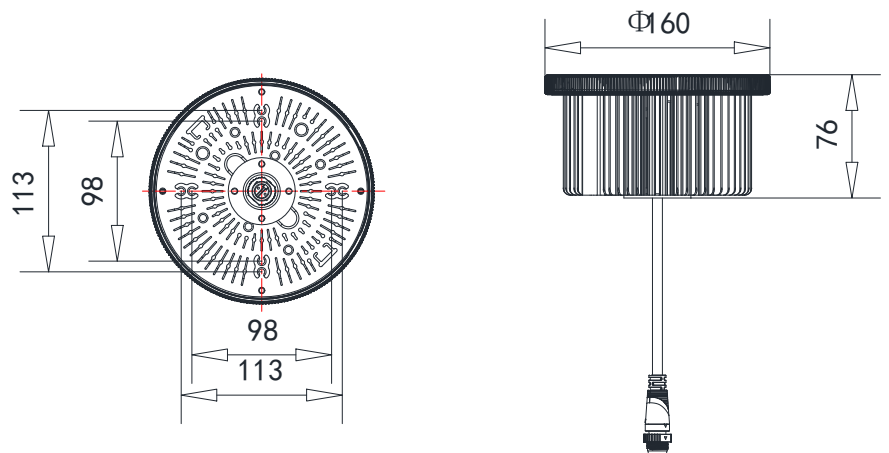

Package Information

L (mm)	W (mm)	H (mm)	Module pcs/carton (PCS)	Package weight (kg)
790	430	145	8	9.4

Values shown are subject to ±5% tolerance.

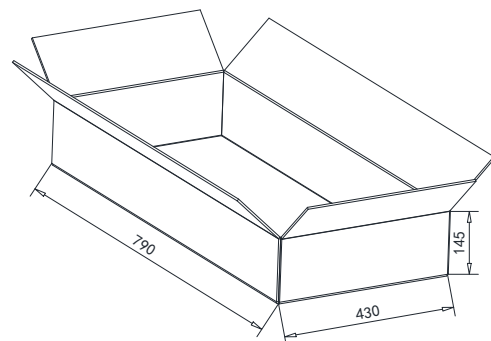
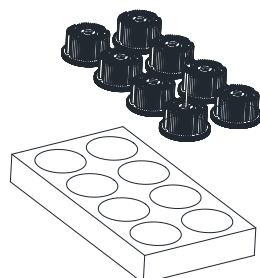

Lighting distributions

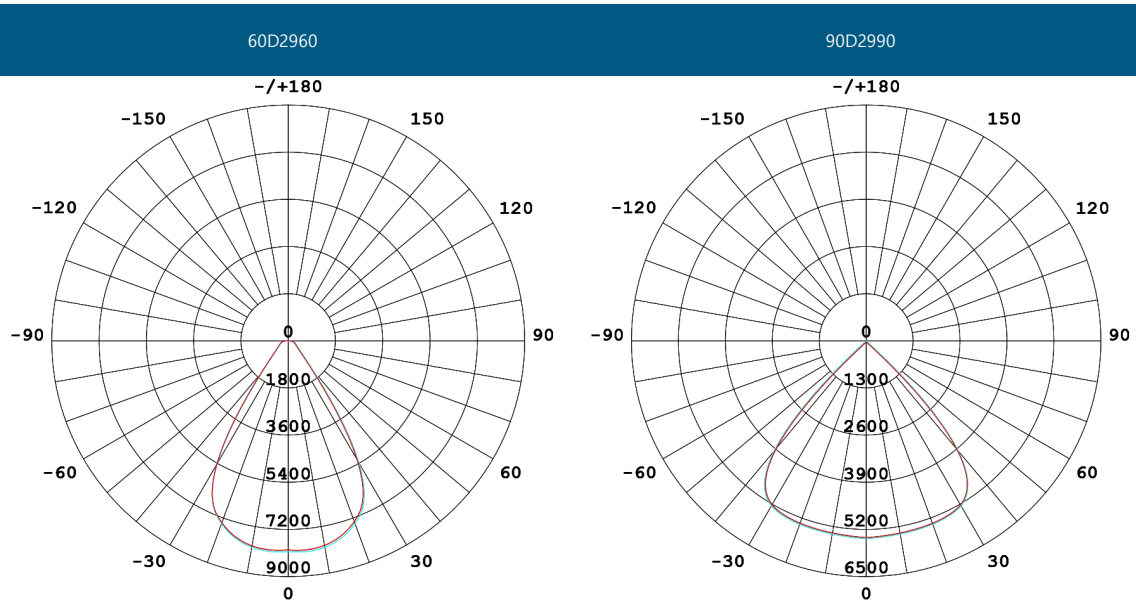

Version History

Change Date	Version	Description of Change		
		Item	From	To
20190905	Ver2.1	Data sheets release (new version)	/	/